

Model No. 3321 Liquid Cooled Rack System (LCRS)



Description

Current systems utilize several rack structures containing multiple individual Line Replaceable Units (LRU), cabled together to perform the necessary electronic functions.

The Liquid Cooled Rack System (LCRS), manufactured by Meggitt Defense Systems, contains and controls the environment for a set of Circuit Card Assemblies (CCA) for use in military aircraft.

The LCRS provides thermal management, structural support and EMI shielding for the CCA housing. The thermal management function is performed by a fluid distribution manifold

assembly and the chassis assembly containing the CCA's, with fluid circulating in the chassis walls. The LCRS incorporates a thermal control valve to provide precise temperature control to the chassis containing the CCA's.

The LCRS has been designed to provide thermal management to CCA's with a maximum heat generation of 3400 watts while maintaining the chassis wall temperature of 20°C to 50°C during normal operations.

The LCRS chassis, with its modular design, can easily be adapted for use in airborne or ground military applications.

Model No. 3321 Liquid Cooled Rack System (LCRS)

TECHNICAL SPECIFICATIONS

- ELECTRICAL POWER :** At fluid temperature of -16.7°C, 3 Φ , 400 Hz, 115 vac power, 2700 watts
 Pump- 300 watts max
 Heater- 2400 watts max
 28 vdc signal power
- HEAT REMOVAL:**
 Heat exchanger type- Plate/ fin
 Heat load: 3500 Watts
 (Includes 300 watt pump load)
- AIR SUPPLY :**
 70,000 ft: -22°C inlet temperature (0.65 psi)
 2.2 in h₂O static pressure.
 Heat exchanger inlet with full dump loss at 8 lbs/min flowrate.
SEA LEVEL: 25°C inlet temperature (14.7 psi)
 2.6 in h₂O static pressure.
 Heat exchanger inlet with full dump loss at 56 lbs/min flowrate.
- FLUID FLOW:** 4.0 gpm (min) PAO entering heat exchanger at 45 °C (max)
- CCA SLOT TEMPERATURE :** 50 °C average across card slot.
- WET WEIGHT :** 90.3 lbs. maximum
- PURGE/FILL PARAMETERS :**
 Total system fluid volume : 176 cu. in. (0.76 Gal.)
 Fill pressure vs temperature at sea level

TEMP. (°C)	PSIG
0	28.5
10	29.5
20	31.0
30	32.5
40	34.0
50	35.0
60	36.5
- THERMAL CONTROL:**
 Fluid temperature is maintained between +20 °C and +35 °C via heat exchanger fluid bypass.
- STATUS SENSORS:**
 Fluid temperature transducers: Resistance type
 High temperature switch:
 48.3 °C max on increasing temperature
 37.8 °C min on decreasing temperature.
 Low temperature switch
 -16.7 °C max on increasing temperature
 -27.2 °C min on decreasing temperature
- FLUID HEATER :**
 2400 watts, 3 phase, 115V, 400Hz

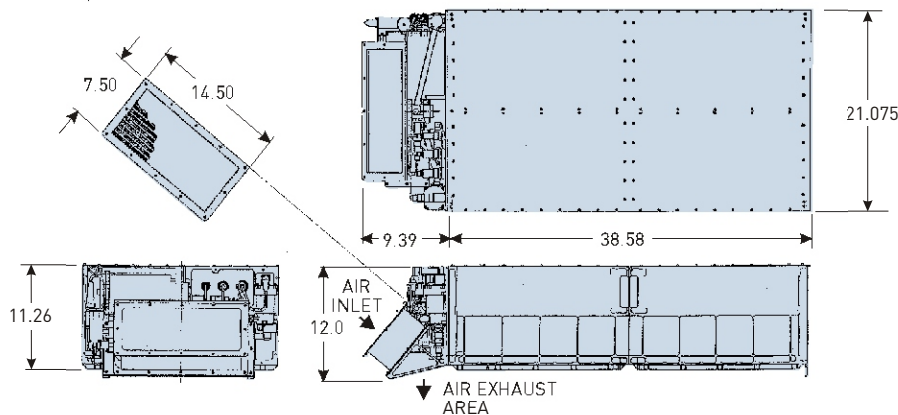

Meggitt Defense Systems Inc
 9801 Muirlands Blvd
 Irvine
 California
 92618
 United States

Tel: 949 465 7700
 Fax: 949 465 9560

www.meggittdefense.com

MEGGITT
 smart engineering for
 extreme environments