

Aeromechanical systems > tow targets

TGX light – augmented radar tow target



Meggitt TGX Light-Augmented Radar Tow Target is an accurate and cost-effective solution for target acquisition and engagement.

Designed to be used as an active naval point defense target for guns, CIWS or missiles, the TGX provides both radar and visual augmentation, as well as, offering the capability to support virtually any current acoustic or Doppler radar scoring system.

The unit's visual augmentation system includes a nose-mounted 600,000 candlepower lamp that is visible at ranges up to 10 kilometers (5 nautical miles) in daylight. The high-intensity light not only allows visual range identification of the target, it also greatly enhances operational safety – giving ships and aircraft a clear view of the oncoming TGX.

The TGX's frontal radar augmentation area is up to 5 square meters (54 square feet) and is provided by a proprietary I/J (X) band radar reflector coaxially mounted in the front of the lamp.

The lighting system, as well as active radar augmentation or other specialized payloads are powered by a compact, 28-volt alternator, which is continuously driven by a ram air turbine located in the tail cone, eliminating the need for heavy batteries.

To help ensure operational flexibility and cost-efficiency, the TGX requires no external support equipment. It can be flown either in a one-way configuration, launched from a Meggitt Defense Systems LTC series launcher or attached to any type of reeling machine and towed behind a commercial or military aircraft configured for carrying external stores. Also, because of its light weight, the TGX can also be flown from a sub-scale or full-scale drone aircraft.

Currently in use by militaries around the world, the Meggitt TGX Light-Augmented Radar Tow Target has proven to be a reliable, low-cost system for optimizing the efficiency and effectiveness of naval or group weapon system use.

Key features

- Low-cost solution for naval or group weapon system use
- Fully compatible with all current acoustic and Doppler radar scoring systems
- Nose-mounted, 600,000 candlepower lamp visible to 10 kilometers (5 nm) in daylight improves visual identification and operational safety
- Radar augmentation up to 5 square meters (54 square feet) at I/J band (10 GHz)
- Continuous on-board electrical power for radar augmentation and special payloads provided by a compact, tail-mounted ram air turbine eliminates batteries
- Available in one-way and two-way tow configurations for military and commercial aircraft, including sub- and full-scale drones
- No specialized support equipment required
- Empty weight of only 30 kilograms (66 pounds)

Meggitt Defense Systems

Our product competencies and services:
Ammunition Handling Systems | Thermal Management | Countermeasures | **Towed Targets** | Electronic Systems

MEGGITT
smart engineering for
extreme environments

Aeromechanical systems > tow targets

TGX light – augmented radar tow target

Specifications

Weight (nominal)	30kg
Dimensions	
fin span	23 inches
diameter	9 inches
length	88 inches
Operable airspeed	
minimum airspeed	180 KIAS
maximum airspeed	450 KCAS or 0.8 mach
Operable altitude	Sea level to 40,000 ft. MSL
Visual augmentation	
lamp voltage	28 VDC
maximum candlepower	600,000
visual range (naked eye)	5 nautical miles (target altitude of 1,000 ft. (305 m.)

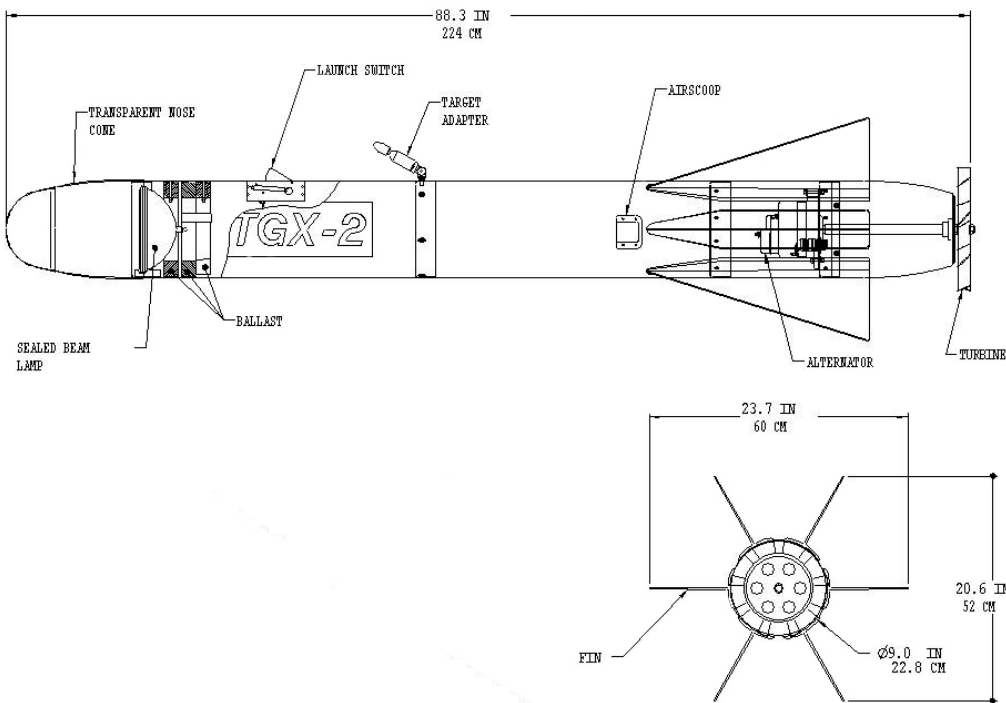

Contact

Meggitt Defense Systems

9801 Muirlands Blvd
Irvine, CA 92618, USA
Tel: +1 (949) 465 7700
Fax: +1 (949) 465 9560

www.meggittdefense.com
www.meggitt.com

Meggitt Defense Systems

Our product competencies and services:
Ammunition Handling Systems | Thermal Management | Countermeasures | Towed Targets | Electronic Systems

MEGGITT
smart engineering for
extreme environments