

**Aeromechanical systems** > tow targets

## TRX Radar augmented tow target



The Meggitt TRX radar-augmented tow target is designed for use with any gun or missile weapons system that requires a radar signature for acquisition, tracking, ranging, guidance or fusing.

The TRX's normally passive radar-augmentation system uses the arrangement of lenses or reflectors to change the target radar signature to effectively emulate a variety of airborne threats.

The TRX also operates within a wide range of bands to meet precision radar signature requirements. Varying Radar Cross Section (RCS) sizes are provided by either the TRX-1 4 passive precision target or through active augmentation. ultra-small, (stealth type) radar characteristics are also available.

To increase the system's value for testing and training, the TRX has the capability to support virtually any current acoustic or doppler radar scoring system.

To help ensure operational flexibility and cost-efficiency, the basic TRX requires no external support equipment. The Meggitt Defense Systems' DHL target loading mechanism and MTL target transporter are optional for support during target buildup, transport and loading.

To ensure multi-mission flexibility, the TRX tow target can be flown with an internal reel and launched in a one-way configuration, or attached to any type of reeling machine and towed behind a commercial or military aircraft configured for carrying external loads. Also, because of its light structural weight, the TRX can also be operated from a sub-scale or full-scale drone aircraft.

The high mission flexibility and low acquisition costs of Meggitt's TRX radar augmented tow target is giving armies and navies around the world an effective tool for ensuring the readiness of their radar-based weapons systems.

### Key features

- Low-cost solution for radar acquisition and tracking and fusing
- Fully compatible with all current acoustic and doppler radar scoring systems
- Configurable RCS augmentation up to 17 square meters (183 square feet) at J band and 10 square meters (108 square feet) at I/X bands
- Monostatic or bistatic radar returns in linear or circular polarization
- Available in one-way and two-way tow configurations for military and commercial aircraft, including sub- and full-scale drones
- TRX basic operations require no specialized support equipment
- Empty weight between 12 and 20 kilograms (26.5 and 45 pounds) depending on configuration
- Generous payload capacity to accommodate a variety of scoring systems

## Meggitt Defense Systems

Our product competencies and services:  
Ammunition Handling Systems | Thermal Management | Countermeasures | **Towed Targets** | Electronic Systems

**MEGGITT**  
smart engineering for  
extreme environments



**Aeromechanical systems** > tow targets

# TRX Radar augmented tow target

## Specifications

<b>Target airspeed</b>	400 KCAS (741 KmCAS) (subsonic)
maximum airspeed stowed in launcher	no restrictions
minimum airspeed in tow	0.9 mach
maximum airspeed in tow	
<b>Weight (nominal)</b>	31.0 lbs (14.0 Kg)
<b>Operable altitude</b>	unlimited
<b>Augmentation</b>	
type of augmentation	octahedral retroreflector array (forward and aft)
coverage (less fuselage shadowing)	omni-directional

## Contact

### Meggitt Defense Systems

9801 Muirlands Blvd  
 Irvine, CA 92618, USA  
 Tel: +1 (949) 465 7700  
 Fax: +1 (949) 465 9560

[www.meggittdefense.com](http://www.meggittdefense.com)  
[www.meggitt.com](http://www.meggitt.com)

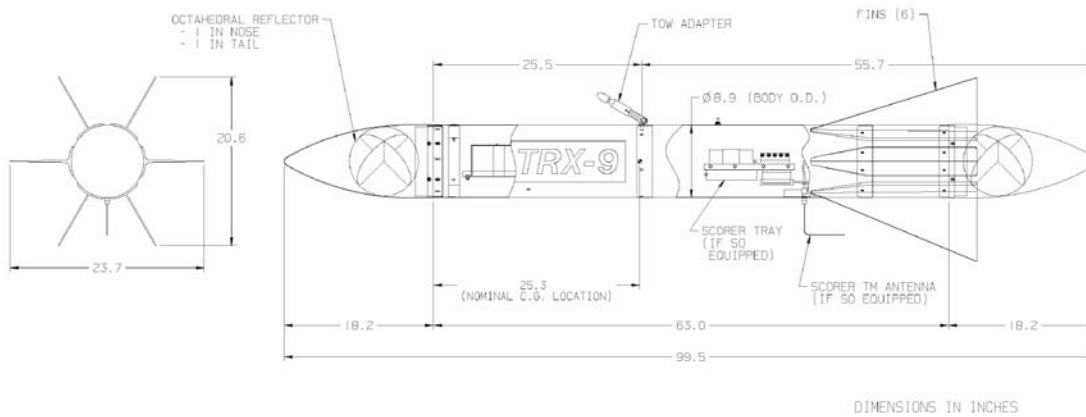

## Meggitt Defense Systems

Our product competencies and services:  
 Ammunition Handling Systems | Thermal Management | Countermeasures | Towed Targets | Electronic Systems

**MEGGITT**  
 smart engineering for  
 extreme environments